

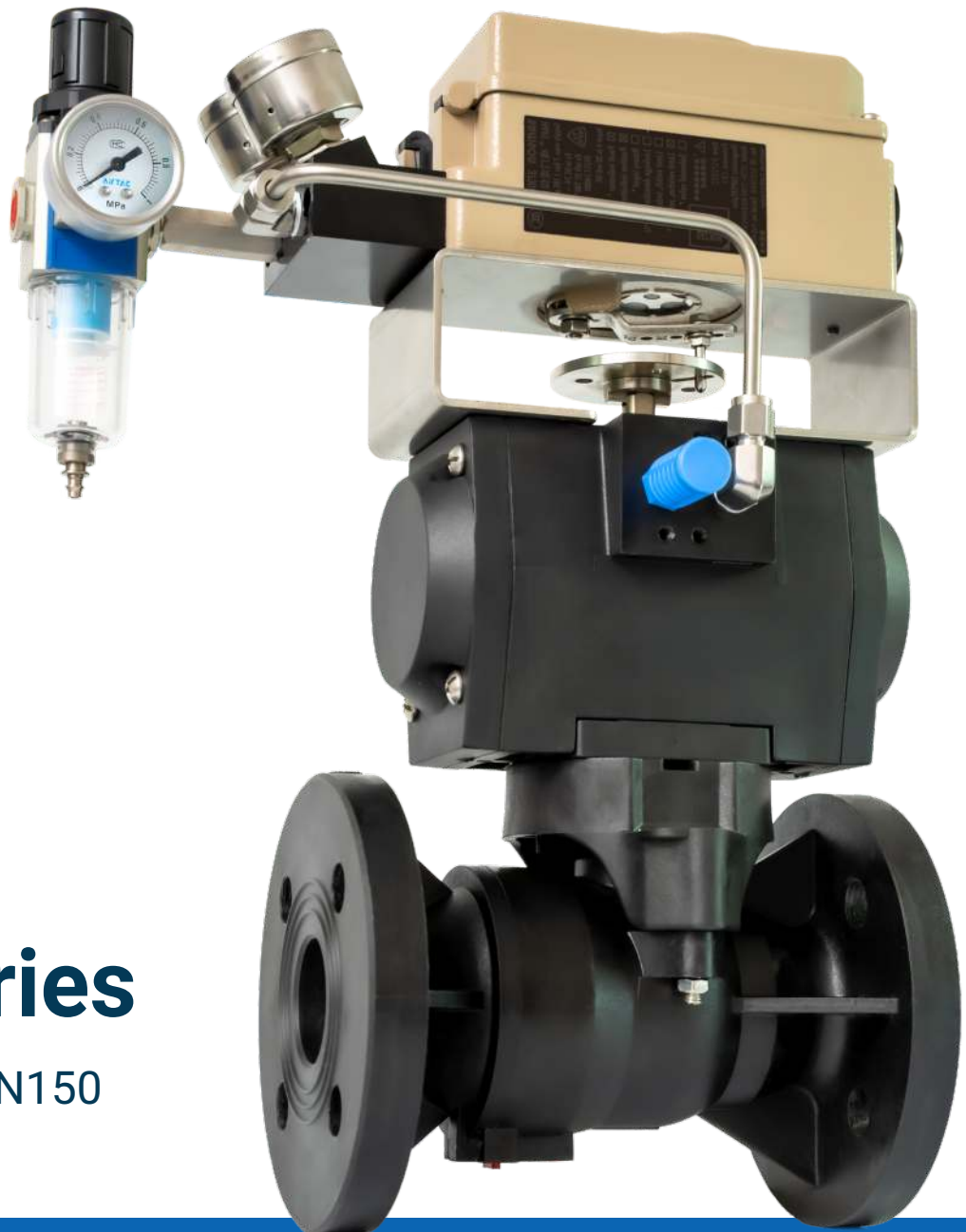

TECHLINK

Associated International Engineers

NON-METALLIC CONTROL VALVES FOR CORROSIVE CHEMICALS



V-Series

DN25 to DN150

FLOW CONTROL PRINCIPLE

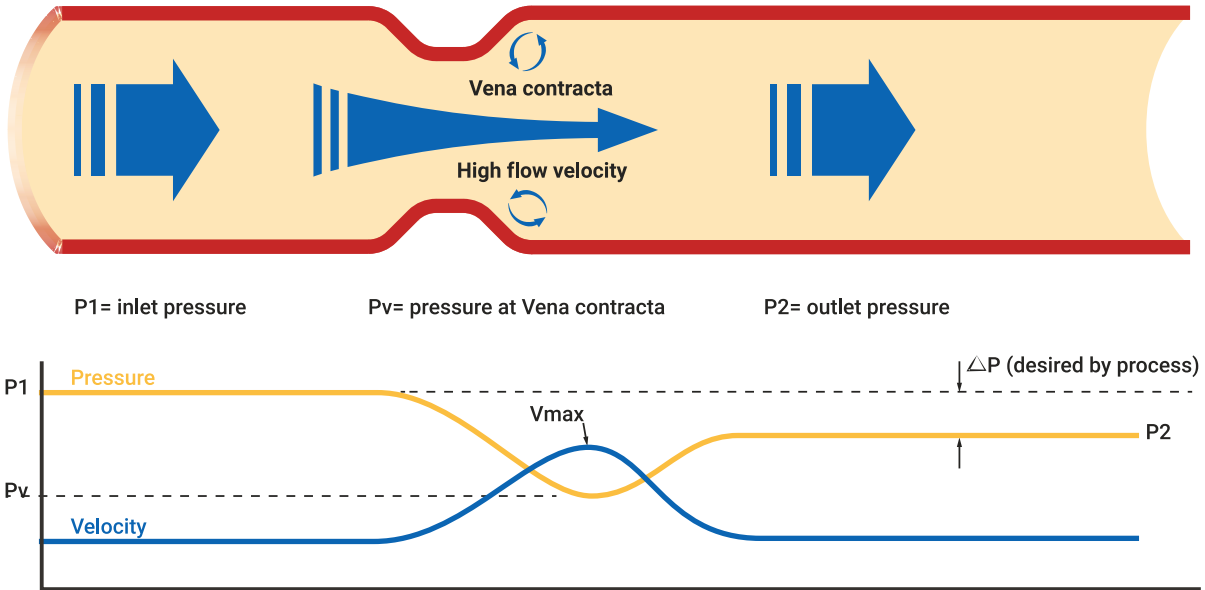

In a control valve, the flow is forced through the control valve orifice by the pressure difference across the valve. The actual flow area is smallest at the point called the vena contracta.

Due to the reduction in flow area, a significant increase in flow velocity has to occur to give equal amounts of flow through the valve inlet area and vena contracta area. The energy for this velocity change is taken from the valve inlet pressure, which gives a typical pressure profile inside the valve.

The pressure inside the valve drops as the effective flow area is reduced, up to the vena contracta point. After reaching the vena contracta point the velocity of the flow is reduced due to the fact that more flow area becomes available to the flow. Thus some of the pressure lost up to the vena contracta point is recovered.

The pressure recovery after the vena contracta point depends on the valve style and type.

The pressure difference (ΔP) between inlet (P1) and outlet (P2) of the valve is what allows the control of liquid flow.

Key points :

- Residual head loss is what we need to control the flow or the pressure
- **Different types of control valves need different pressure drop for the same resulting ΔP**
- High pressure drop means high velocity rise
- High flow velocity is damaging to the trim materials
- **Low velocity means longer life**
- Low-pressure recovery designs improve lifetime

Accuracy and precision:

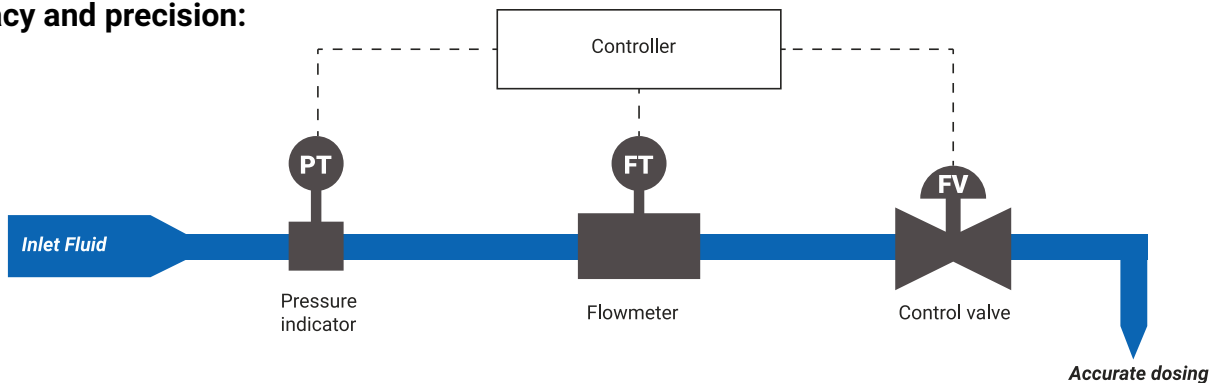

Precision and accuracy of flow control can only be achieved with a control loop. This control loop is programmed integrating inputs and outputs of the flow control equipment.

VALVE MATERIAL

Where the flow velocity is high, corrosive chemicals cause unexpected kinds of damage to the materials. In the vena contracta, metals will show signs of erosion-induced corrosion, even if they are corrosion-resistant as piping or body materials. PFA or PTFE lining will erode quickly, particularly when the valve is used with a high delta-P. Once eroded, the base metal, usually cast iron, is quickly attacked, causing a severe leakage to the outside. TECHLINK non-metallic flow control valves are the longest lasting solution for controlling the flow of corrosive water based chemicals because no metals are used in the construction of the flow related components.

WHY NON-METALLIC MATERIALS?

The corrosion resistance of metals is generally appreciated in still fluids (static situation). But at high flow speeds and in the presence of turbulence, a process known as « erosion induced corrosion » starts destroying even the so-called « corrosion resistant » metals.

In such situation, solid polymers may offer an economic solution, that will outperform even “special metals” and other exotic materials.

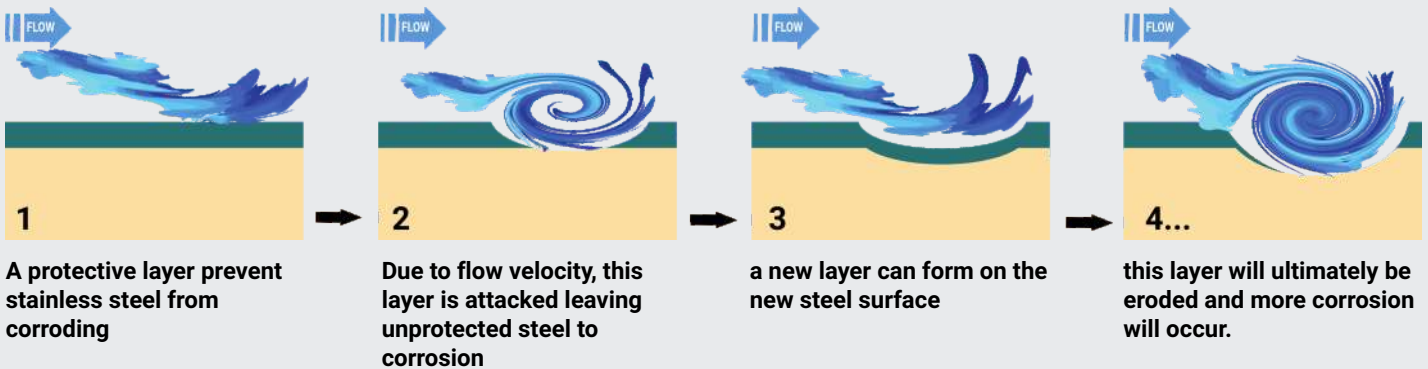

BEST CHOICE IN POLYMER MATERIALS

Polymers are not equal when it comes to resisting high flow velocities, turbulence and erosion, as well as chemical attack. The table below shows the abrasion resistance of several polymers, as determined by the “TABER” ASTM D4060 test. The lower the figure, the better is the resistance.

Apart from polyamid, which cannot be used because of its low chemical resistance, the best abrasion resistant material is PVDF. This material should be preferred for all parts of the valve making up the “Vena contracta”

Key points :

- PVDF is best : Chemical resistance & Erosion resistance**
- PPH or ECTFE is the best alternative where possible**

Material	Weight loss (mg/1000 rev.) ASTM D4060, wheel CS-10
PVDF homopolymer (SOLEF®)	5 - 10 ✓
PVDF, SOLEF® 21508/31508	5 - 8 ✓
PA 6 polyamid	5
ECTFE, Halar®	13 ✓
PP homopolymer	15 - 20 ✓
PTFE	500 - 1000 ⚠
304 stainless steel	50

When PVDF cannot be used for chemical reason, such as in concentrated hydroxides, then PPH and ECTFE are acceptable alternatives. It is readily seen that PTFE, which has the lowest abrasion resistance of all polymers, is the worst choice for contact with the flow in the Vena Contracta.

VALVE DESIGN

The range of TECHLINK compact control valves type V covers flows of 1 m³/h to 150 m³/h under 1 bar ΔP , with either a linear response, or an Equal Percentage response. The shaped V-masks, made of PPH or PVDF, are precisely machined to obtain stable and reproducible flow rates adapted to each process situation.

It is well known that ordinary ball valves are not suitable for flow control. The addition of a shaped mask in front of the ball completely changes this situation. The mask forms a "variable area orifice", partially limited by the ball. As the ball turns, the passage area increases. The shape of the mask determines the control characteristic of the valve.

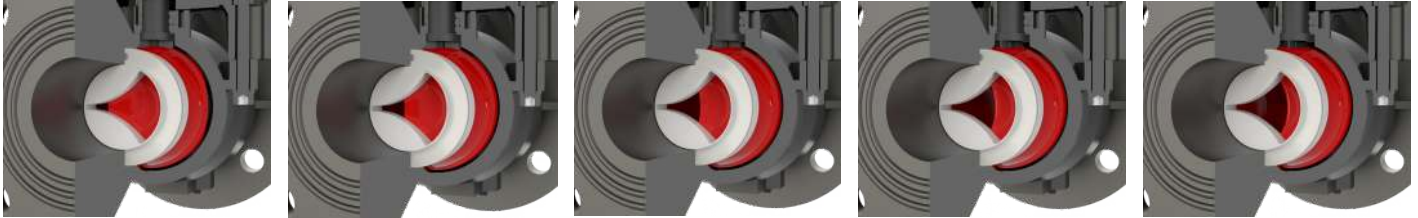

HIGH PERFORMANCE HYDRODYNAMIC DESIGN :

This concept is different from V-shaped and C-shaped balls. In TECHLINK's design, the soft PTFE seat is not impacted by the high velocity flow of the vena contracta. By virtue of hydrodynamics, the point where the velocity is fastest is in the middle of the ball, away from any surfaces that could be impacted by erosion.

Acting like an orifice plate, the mask offers the required delta-P without much flow velocity. The erosive effect is therefore limited, and the Liquid Pressure Recovery Factor FL is almost as high as that of globe valves. Cavitation and turbulences are therefore limited, providing low noise, low vibration, and a long lifetime.

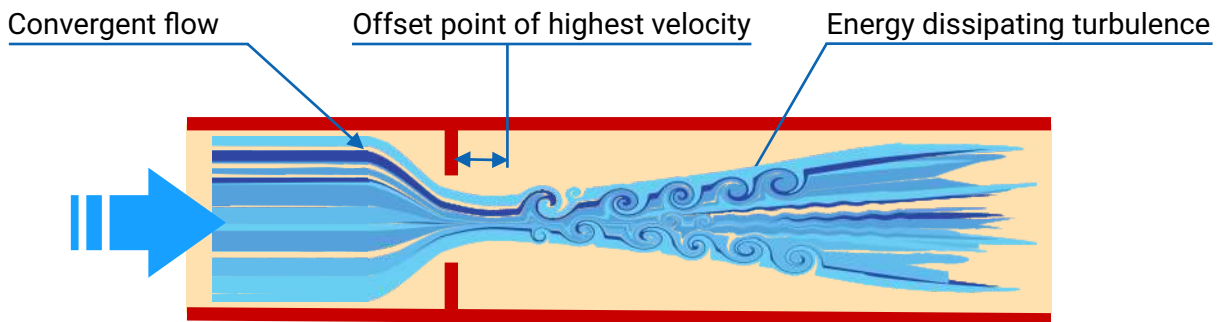

OUTLASTING OTHER TYPES OF CONTROL VALVES

V-port Ball Valves from Techlink are by far the best choice for handling water based corrosive chemicals, even when laden with abrasive particles.

Through the combination of :

- Abrasion resistant polymers selected from the table on the left,
 - High pressure recovery factor providing the required pressure loss with a limited flow velocity in the vena contracta,
 - Protection of soft PTFE seats from the flow,
- they outperform and outlast fluoropolymer lined steel valves, most high nickel alloy valves, and all cases of diaphragm valves.

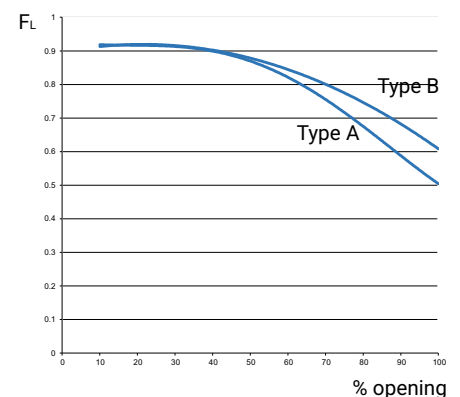

ROBUST PRECISION DOSAGE WITH NO COMPROMISE

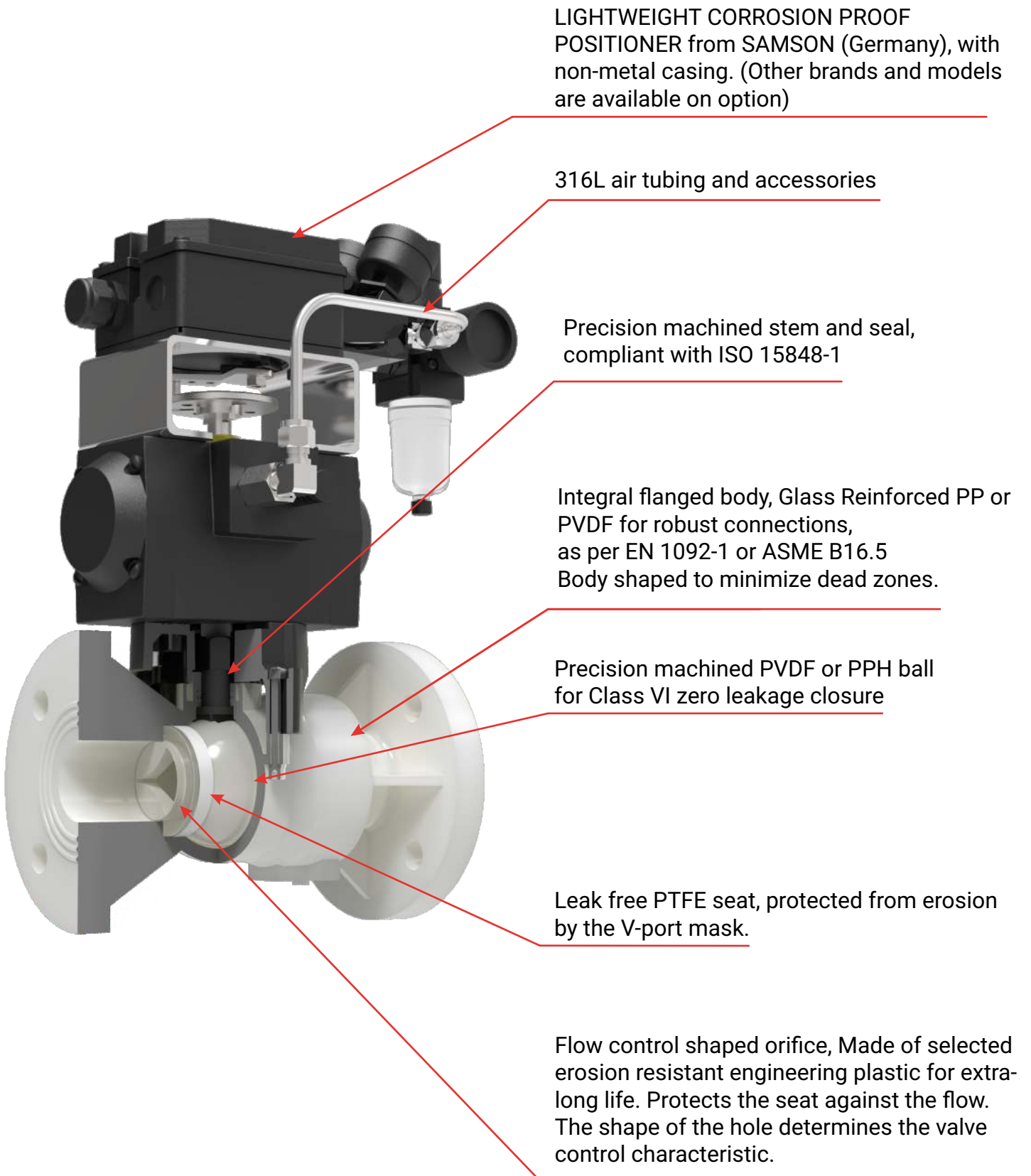

TECHNICAL DATA

PRESSURE RANGE	VACUUM TO 1 Mpa G
TEMPERATURE RANGE	-5°C to 80°C (PPH) 100°C (PVDF)
CONNECTION STYLE	FLANGED
CONNECTION SIZES	DN 25 to DN 150
FLANGES STANDARDS	EN 1092-1 PN10 , or ASME B16.5 150#
FACE-TO-FACE LENGTH	EN 558-1
BODY MATERIAL	PPGF (Glass reinforced) or PVDF
BALL MATERIAL	PPH (up to DN50), PPGF (>Dn50) or PVDF
SEATS MATERIAL	PTFE
O-RINGS MATERIALS	EPDM or FKM or FFKM
BOLTING AND FITTINGS	316 L
STEM SEAL	O-RING, ² WITH ISO 15848 performance
ACTUATOR TYPE	RACK & PINION
ACTUATOR BODY MATERIAL	POLYARYLAMIDE OR ALUMINIUM
MIN. AIR PRESSURE REQUIRED	0.45 Mpa
FAIL ACTION	OPEN, CLOSE, or DOUBLE ACTION
POSITIONER TYPE	FLAP & NOZZLE
POSITIONER (RECOMMENDED)	SAMSON 3725 or 3730
TRIM TYPE	EQUAL % or LINEAR
TIGHTNESS CLASS	CLASS VI (IEC 60534-4)

PRESSURE/TEMPERATURE RESISTANCE CURVES

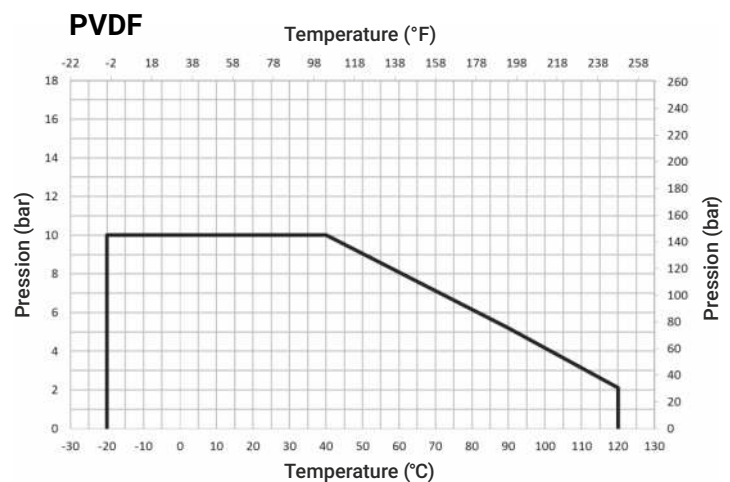
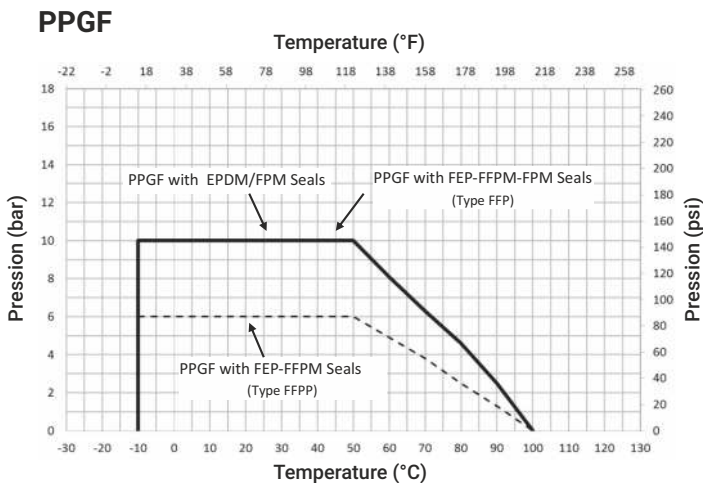

MATERIALS LIST

Item #	Description	Material
1	Positionercover	Polycarbonate (Samson 3725). As per model for other options
2	Positioner body	Polyphthalamide (PPA)(Samson 3725). As per model for other options
3	Gauges	316 L
4	Tubing and fittings	316 L
5	Actuator body	Polyarylamide, or Anodized Aluminium
6	Actuator support	Glass reinforced PP (PPGF)
7	Stem seal (Oring)	EPDM or FKM or FFKM
8	Body O-rings	EPDM or FKM or FEP encapsulated VMQ
9	Seat O-ring	EPDM or FKM or FFKM or FERencapsulated FKM
10	Ball	PP (up to DN50), PPGF (3" to 6") or PVDF
11	Seats	PTFE
12	Body	Glass reinforced PP (PPGF) or PVDF
13	V-port orifice	PPH or PVDF

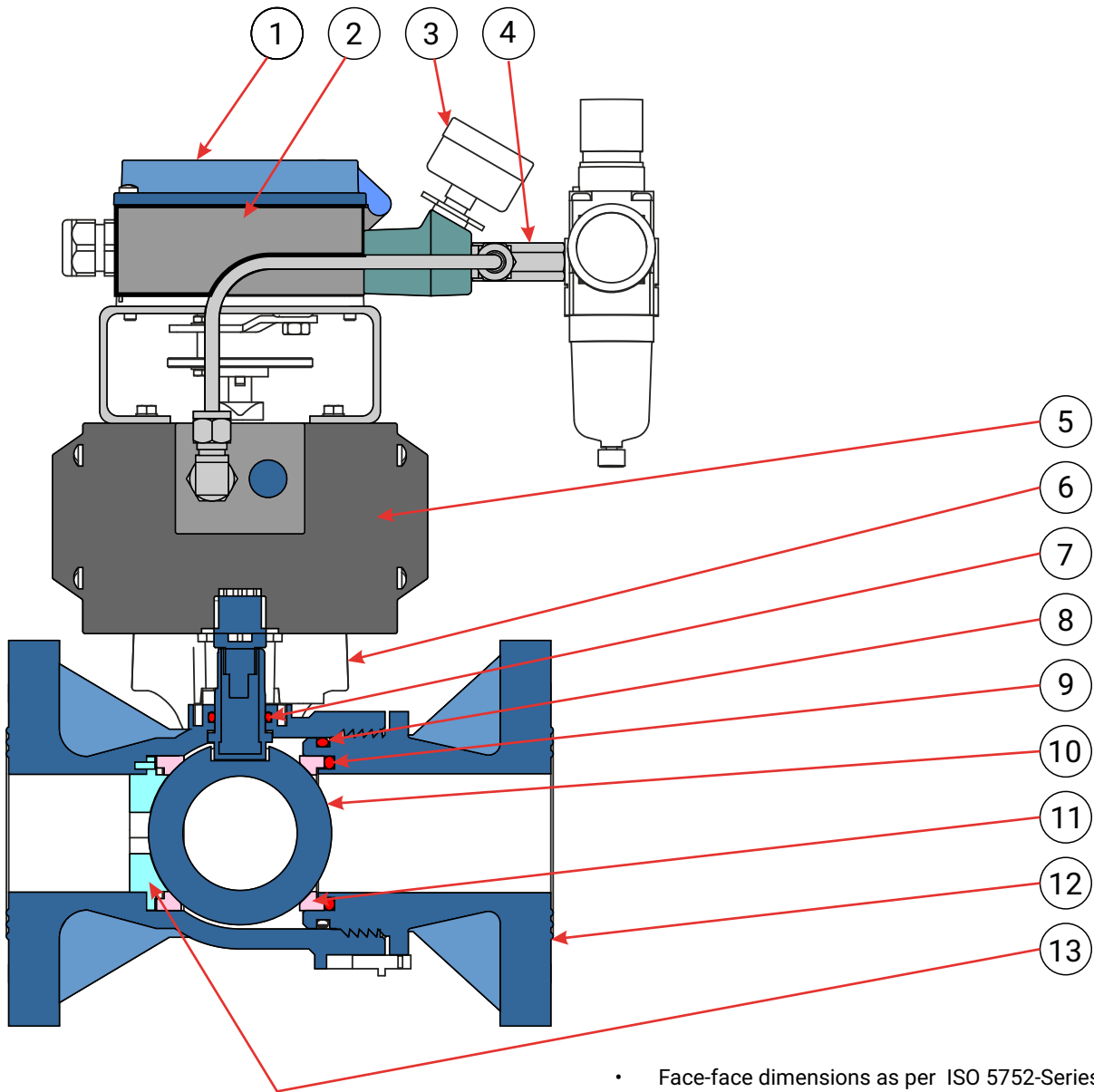

- Face-face dimensions as per ISO 5752-Series 1
- Flange drilling as per DIN 1092-1/ISO 7005 Pn10 or ASME B16.5 150#

OVERALL DIMENSIONS

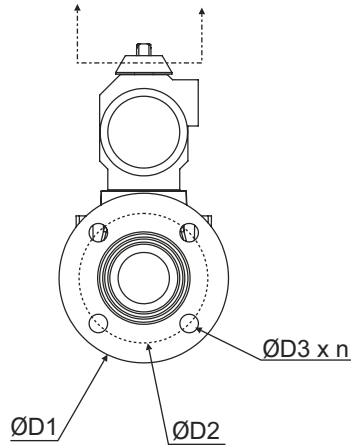
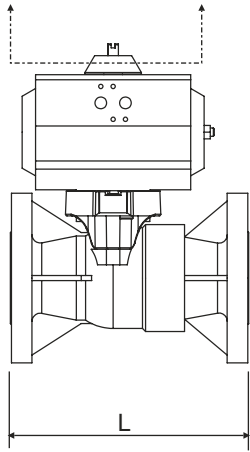

DN	ØD1 mm	ØD2 mm	ØD3 mm	n	L mm
25	115	85	14	4	160
40	150	110	18	4	200
50	165	125	18	4	230

FLANGES AS PER PN 10 HG/T 20592(A), FF

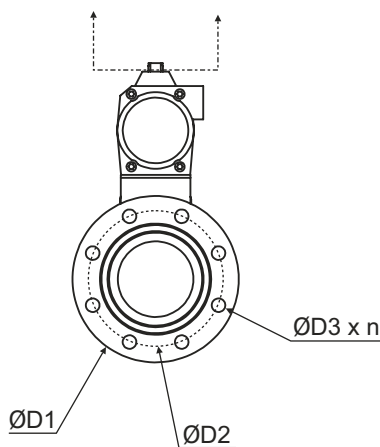
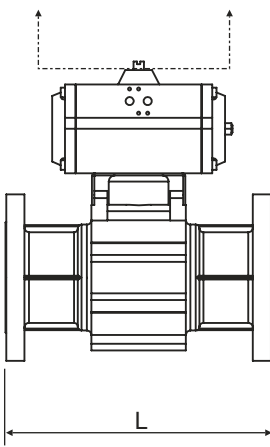

DN	ØD1 mm	ØD2 mm	ØD3 mm	n	L mm
80	200	160	18	8	310
100	220	180	18	8	350

FLANGES AS PER PN 10 HG/T 20592(A), FF

FLOW CONTROL RESPONSE CHARACTERISTICS

TECHLINK non-metallic V-Type control valves can be delivered with a linear characteristic or equal percentage characteristic of various depth. All our models are tested on our test loop. Individual valves may, at the customer's request, be loop-tested, and the test report delivered with the valve.

The graph on the right shows a typical characteristic curve of equal percentage V-Type ball valves. Three types of profiles are available, providing different Equal % responses. Our engineers will calculate the most suitable combination from the customer's process data.



V-port Type S
(Semi-linear)



V-port Type A
(Eq%)



V-port Type B
(Eq%)

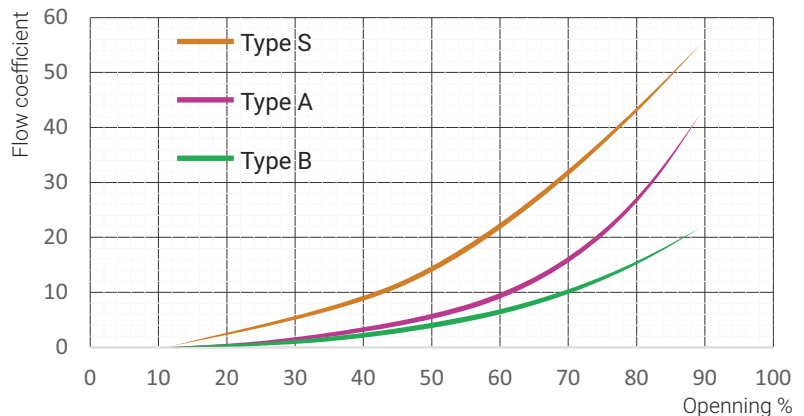

ASSEMBLY EXPERTISE

A TECHLINK non-metallic V-Type control valve can be delivered with either a LINEAR characteristic or an EQUAL PERCENTAGE characteristic. All our models are tested on our test loop. Individual valves may, at the customer's request, be loop-tested, and the test report delivered with the valve.

Our engineers will calculate the most suitable combination of size and V-port contour from the customer's process data.

They will also advise on the best equipment suitable to the process:

To avoid undesirable stress and deformation of the valve structure, the associated accessories should be as light as possible. Whenever they exist, and except when they are prohibited by explosion zone rules, equipment with non-metallic bodies or casing are preferred. Heavy top-work needs to be supported and is not recommended.



POSITIONERS

TECHLINK control valves are normally fitted with SAMSON positioners type 3725 or 3730. Different options are available.

Model 3725 is recommended for its favorable cost and its corrosion-proof plastic casing.

Models of the 3730 series are recommended for their options, and highest precision.

Positioners of other brands are available on request, subject to prior testing and validation.

Positioner auto-tune, and valve functional testing is always performed on our valves, which are supplied "ready to use".



TECHLINK FLOW CONTROL VALVES PRODUCT CODES

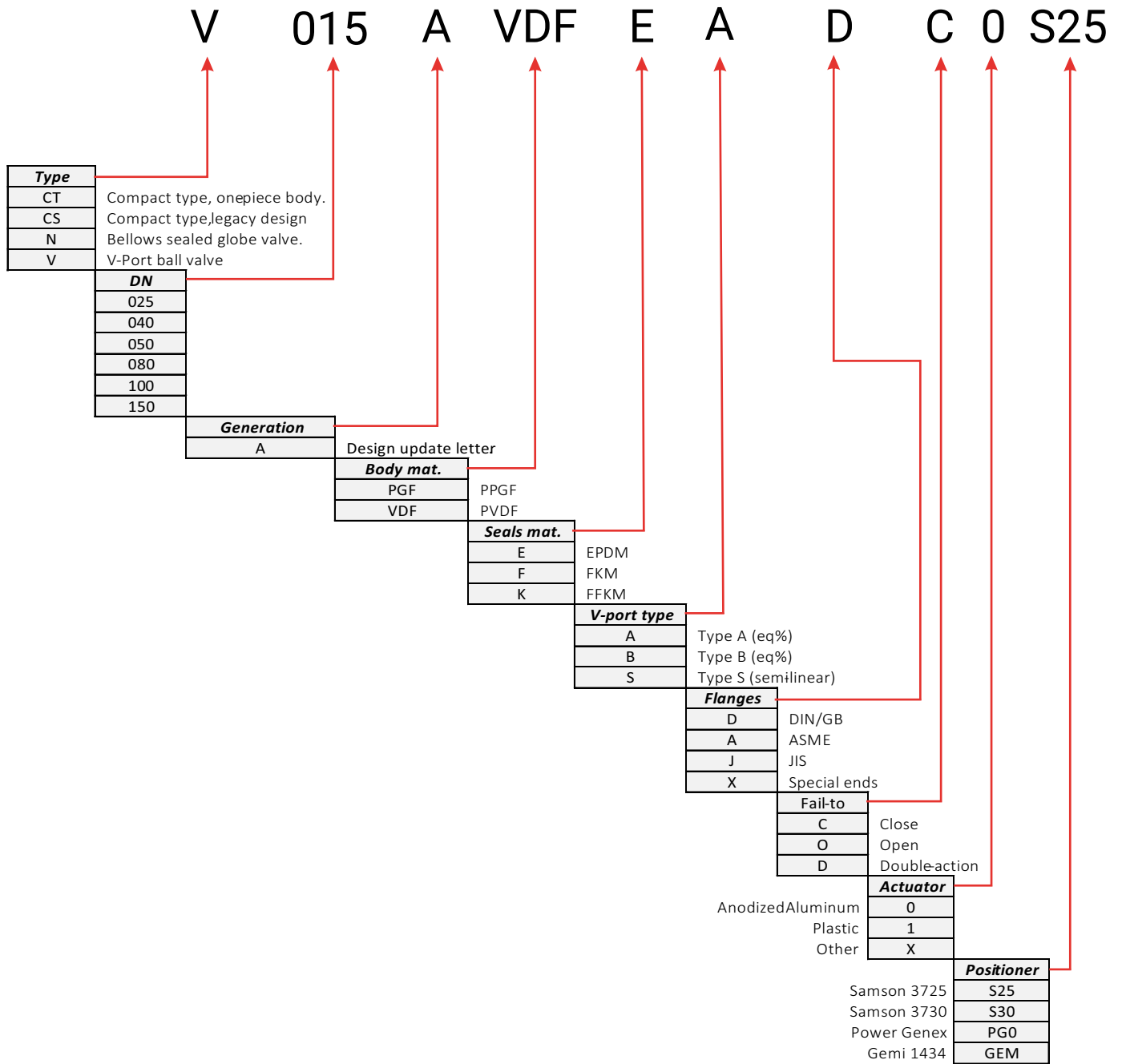



**State of the art innovation in flow control of
corrosive chemicals.**



FRANCE (HEADQUARTER)

TECHLINK Sarl

4c rue de la Ladrie
59290 Wasquehal
FRANCE

Tel : +33 320 05 00 45

www.techlink.fr

CHINA

TECHLINK SHANGHAI LTD.

Room 306 & 307, n758 Songsheng road,
Songjiang District,
Shanghai 201614, P.R. CHINA

Tel : + 86 21 57783957, 57783967

FAX : + 86 21 57784017

www.tech-link.asia

THAILAND

TECHLINK BANGKOK

Thai Virawat building
16TH floor, 16F
86/1 Krungthonburi Road,
Klongsan 10600,
THAILAND

Tel : +66896606955

www.tech-link.asia

INDIA

TECHLINK International Process Engineers Pvt. Ltd.

111 - Bholesal Complex, 3rd floor,
Main road, Cha Rasta, Fatehpura,
Vadodara - 390006
Gujarat, INDIA

Tel : +91 265-2324255

Mob: +91 8128057025

www.tech-link.com